

Practical Aspects of Creating a Teacher's Information Space

Authors:

Inna Muzyleva, Lipetsk State Technical University, Lipetsk, Russian

Liubov Yazykova, Lipetsk State Technical University, Lipetsk, Russian

Anzhelika Martynova, Lipetsk State Technical University, Lipetsk, Russian



Speaker's

Inna Muzyleva

Lipetsk State Technical
University, Lipetsk, Russian



Liubov Yazykova

Lipetsk State Technical
University, Lipetsk, Russian

Practical aspects of creating a teacher's information space

THE MAIN IDEAS

- The methodology of creating a personal information space of a teacher is presented;
- The form of this space is a teaching site with teaching materials;
- The methodology of posting structured content on a WordPress blog ;
- A method for creating media content for special disciplines of technical areas of training ;
- A step-by-step methodology for creating a video lesson in the Camtasia Studio program based on the Power Point presentation.

Practical aspects of creating a teacher's information space

THE RELEVANCE OF THE PROBLEM

- The concept of modernization of modern education is digitalization and the training of a specialist familiar with the features of the industrial revolution 4.0;
- Insufficient quality media content for higher education;
- Inadmissibility of self-education of students in technical disciplines;
- Clip -thinking is typical for the entire generation. Therefore, students need to repeat the assimilation of the material;
- A face-to-face lecture lesson needs to be supported by the media content posted on the network so that the student can consolidate, repeat or master again the material explained at the lesson.

Practical aspects of creating a teacher's information space

METHODICAL SITE AS A PERSONAL INFORMATION SPACE OF A TEACHER

This is a training center, available 24/7

Material is structured to several mandatory components:

- 1) Theoretical material in the form of
 - a) A text file and / or;
 - b) Multimedia presentation and / or;
 - c) Video lesson;
- 2) A practical task, with personal, regularly updated options. It can be:
 - a) Tasks;
 - b) Calculation tasks;
 - c) Message topics, etc.

Practical aspects of creating a teacher's information space

METHODICAL SITE AS A PERSONAL INFORMATION SPACE OF A TEACHER – THE PRACTICAL IMPLEMENTATION:

Website - “Learning Digital Technology” <http://cifra.studentmiv.ru/> ;

The hosting - Gino <https://jino.ru/> ;

Standard platform blog - WordPress;

Theme - Weaver II:

- 1 - Each discipline = a site page;
- 2 - Current teacher schedule;
- 3 - Interdisciplinary material.

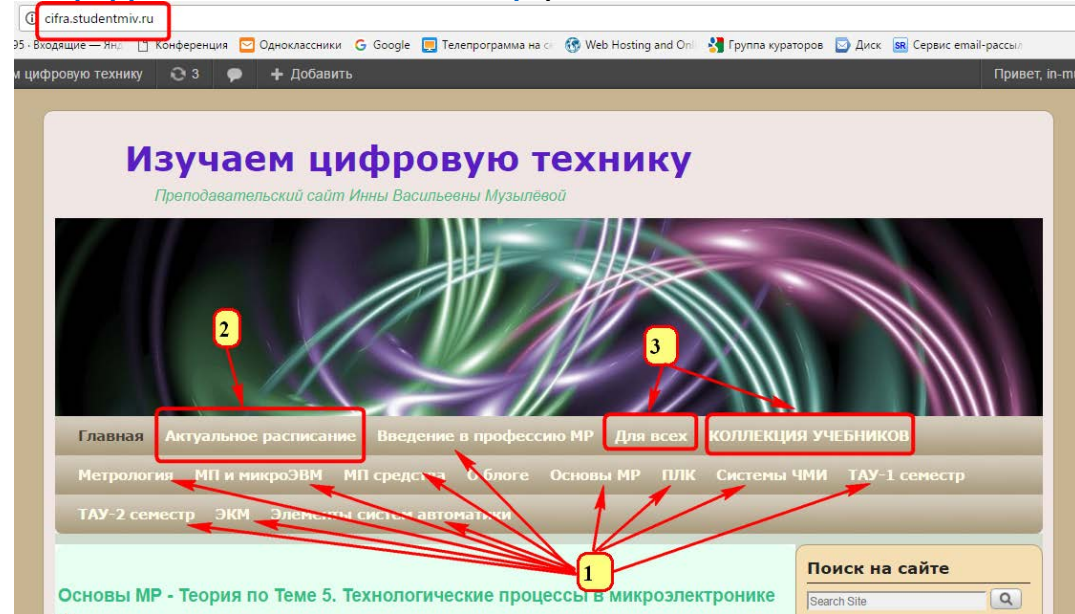

Practical aspects of creating a teacher's information space

Block module of discipline:

- Discipline Page – in the site menu;
- Module pages – child pages.

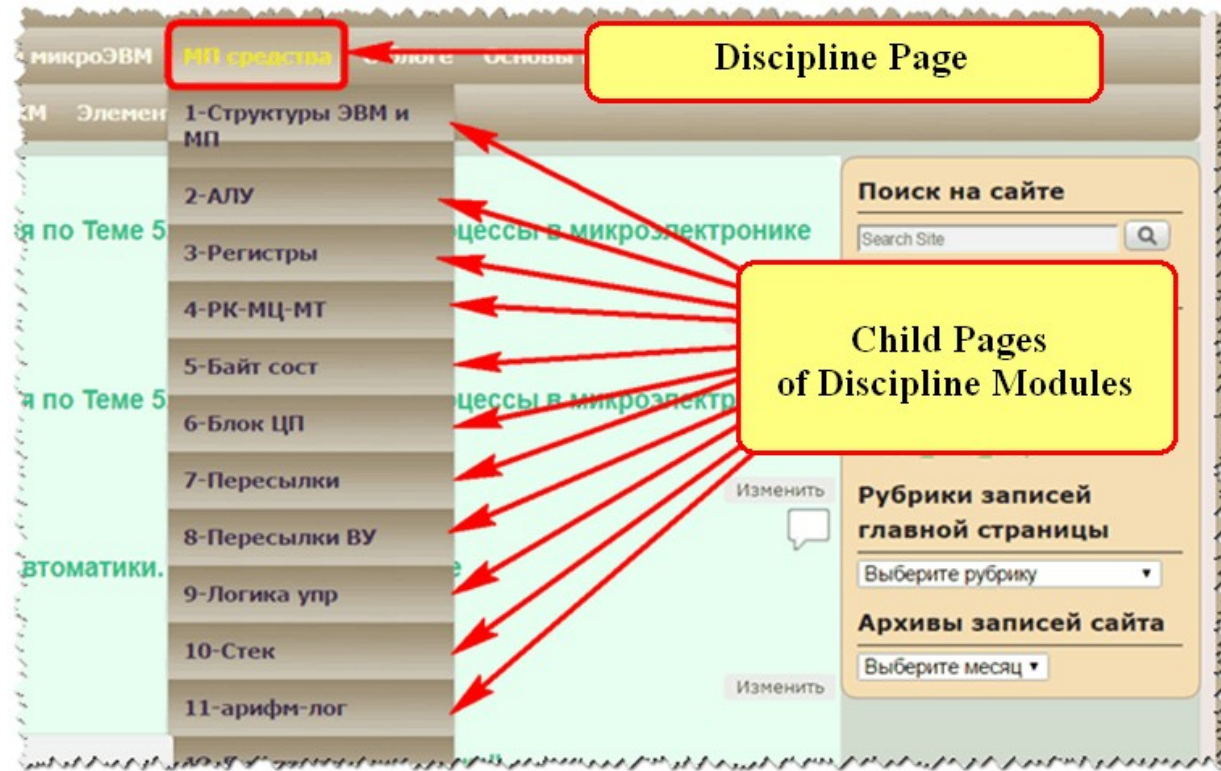

Practical aspects of creating a teacher's information space

Linking to the video course and individual videos on the author's site

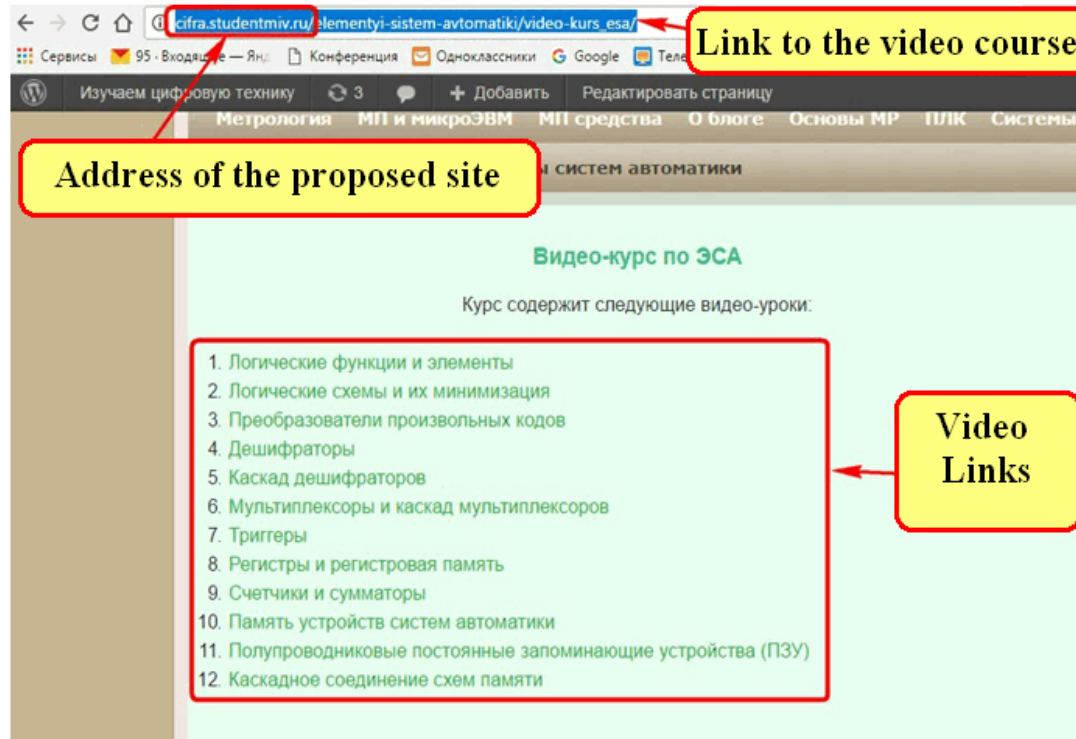

The screenshot shows a web browser window with the address bar containing `cifra.studentmiv.ru/elementy-sistem-avtomatiki/video-kurs_esa/`. A red box highlights this address with the label "Address of the proposed site". The page content includes a navigation menu with items like "Метрология", "МП и микроЭВМ", "МП средства", "О блоге", "Основы МР", "ПЛК", and "Системы". The main heading is "Видео-курс по ЭСА" (Video course on ECA). Below it, a list of 12 video lessons is provided, enclosed in a red box with the label "Video Links". A red arrow points from the label "Link to the video course" to the end of the URL in the address bar.

Address of the proposed site

Link to the video course

Video Links

1. Логические функции и элементы
2. Логические схемы и их минимизация
3. Преобразователи произвольных кодов
4. Дешифраторы
5. Каскад дешифраторов
6. Мультиплексоры и каскад мультиплексоров
7. Триггеры
8. Регистры и регистровая память
9. Счетчики и сумматоры
10. Память устройств систем автоматики
11. Полупроводниковые постоянные запоминающие устройства (ПЗУ)
12. Каскадное соединение схем памяти

STAGES OF CREATING A VIDEO LESSON

- 1) To create a presentation;
- 2) To write text for audio accompaniment - no more than 5-7 minutes;
- 3) Audio recording in Camtasia Studio;
- 4) The synchronization of audio recordings and presentations in Power Point;
- 5) The imposition of explanatory elements on the presentation (arrows, strokes, highlighting, explanatory text, etc.) in synchronization with audio accompaniment;
- 6) To convert a video file in mp4 format.

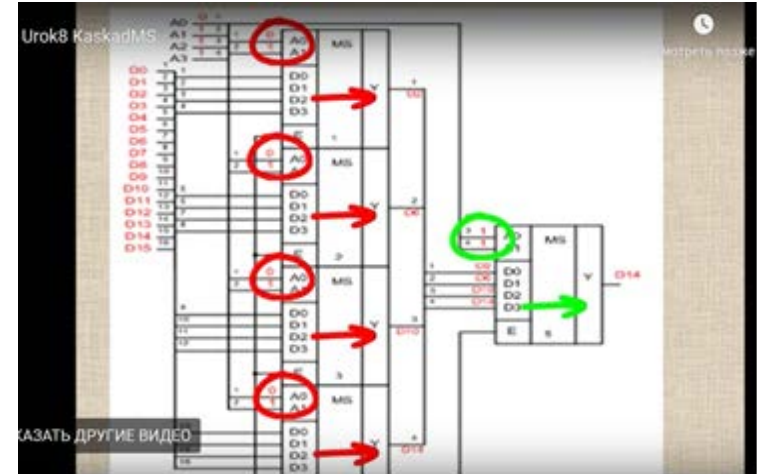

Practical aspects of creating a teacher's information space

CONCLUSION

- Teaching site is a modern form of personal information space of a higher education teacher.
- It contains methodological content in disciplines, interdisciplinary content and provides the basics of the teacher's time management.
- The “stop - repeat” mode allows the student to master the material at a comfortable pace and at any convenient time.
- The most promising form of media content is a video lesson. This is the best way to pass information to generation Z.
- For the teacher, the creation of video lessons allows you to structure the material and check the level of competencies.

Thank you for attention!

Speaker's contacts:



Speaker's

Inna Muzyleva

Lipetsk State Technical University, Lipetsk, Russian

e-mail: lstu-miv2010@yandex.ru

web-site <http://cifra.studentmiv.ru/>